



Evaluation Report CCMC 13490-R AiRclad (Air Barrier Material)

MASTERFORMAT:	07 27 09.02
Evaluation issued:	2013-12-20
Revised:	2015-09-11
Re-evaluation due:	2016-12-20
Re-evaluation in progress	

1. Opinion

It is the opinion of the Canadian Construction Materials Centre (CCMC) that “AiRclad (Air Barrier Material)”, when used as an air barrier material in accordance with the conditions and limitations stated in Section 3 of this Report, complies with the National Building Code 2010:

- Clause 1.2.1.1.(1)(b), Division A, as an alternative solution that achieves at least the minimum level of performance required by Division B in the areas defined by the objectives and functional statements attributed to the following applicable acceptable solutions:
 - Sentence 5.4.1.2.(1), Air Barrier System Properties
 - Sentence 9.25.3.2.(1), Air Barrier System Properties

This opinion is based on CCMC's evaluation of the technical evidence in Section 4 provided by the Report Holder.

Ruling No. 15-01-322 (13490-R) authorizing the use of this product in Ontario, subject to the terms and conditions contained in the Ruling, was made by the Minister of Municipal Affairs and Housing on 2015-01-05 pursuant to s.29 of the Building Code Act, 1992 (see Ruling for terms and conditions). This Ruling is subject to periodic revisions and updates.

2. Description

This Report addresses the performance of the product as an air barrier material within the Plastiques Cellulaires Polyform-specified “AiR-clad” air barrier system. This air barrier system has not been evaluated, but is presented in Appendix A as additional information for the convenience of building officials and designers.

The product's material, if installed as part of the designated air barrier system, will serve a dual function in the wall assembly. Use of the product as a sheathing membrane to control incidental water infiltration behind cladding is covered under a separate CCMC Evaluation Report (see CCMC 13488-R).

The product is a Type 2, preformed, moulded, expanded polystyrene rigid insulation panel. The panels are plant-laminated to a spun-bonded olefin sheathing membrane (“Tyvek® Homewrap™,” CCMC 12808-R, made by E.I. duPont Canada Company) with a hot melt adhesive that is applied every 20 mm in three 2-mm strips and spaced 5 mm on centre. The panels are commonly 2 438 mm x 1 219 mm or 2 743 mm x 1 219 mm in size and are available in 12.7-mm- to 76.2-mm-thicknesses.

3. Conditions and Limitations

CCMC's compliance opinion in Section 1 is bound by the “AiRclad (Air Barrier Material)” being used in accordance with the conditions and limitations set out below.

- The product's material has demonstrated a sufficiently low air permeance equivalent to the materials outlined in Appendix Note A-9.25.5.1.(1), Air Vapour Permeance Values, and Sentence 5.4.1.2.(1) of Division B of the NBC 2010, to be the principal plane of airtightness in an air barrier system.

- When the material is installed as part of the airtight element of the designated air barrier system, the vapour barrier must generally comply with Sentences 9.25.4.2.(1), (2), (5) and (6), Vapour Barrier Materials, of Division B of the NBC 2010. In cases where another low water vapour permeance element has been installed in the wall assembly, Sentences 9.25.4.2.(3) and (4) apply.
- A conforming installation must be:
 - installed with the printed side facing outward and protected from exposure to ultraviolet (UV) radiation from the sun within 60 days;
 - installed with a minimum 10-mm air space between the sheathing membrane and the cladding, unless the cladding has been deemed to not require an air space (e.g. deemed by CCMC or deemed by building officials based on past cladding performance); and
 - installed according to the most recent version of Plastiques Cellulaires Polyform’s “AiRclad” Installation Manual (examples of the installation details are presented as Additional Information in Appendix A).
- It should be noted that a concealed air space exceeding 25 mm in width must contain proper fire stopping, in accordance with Sub-section 9.10.16., Fire Blocks, of Division B of the NBC 2010.
- CCMC-evaluated sheathing tape must be used to seal all joints.

4. Technical Evidence

The Report Holder has submitted technical documentation for CCMC’s evaluation. Testing was conducted at laboratories recognized by CCMC. The corresponding technical evidence for this product is summarized below.

The durability assessment of the product is covered under CCMC 13488-R.

4.1 Performance Requirements

The Report Holder has submitted technical documentation for CCMC’s evaluation. Testing was conducted at laboratories recognized by CCMC. The corresponding technical evidence for this product is summarized below.

Table 4.1.1. Results of Testing the Product to the CCMC Technical Guide for Air Barrier Materials

Test	Requirement	Result
Five 1-m ² membrane specimens tested and measured for air permeance at a minimum of six air pressure differentials (DP) between 0 and 250 Pa	Air leakage rate at 75 Pa ΔP (based on linear regression of 30 data points) ≤ 0.02 L/(s·m ²)	0.0174 L/(s·m ²)

Table 4.1.2. Results of Testing the Product to the CCMC Technical Guide for Air Barrier Materials

Property	Unit	Requirement	Result
Water vapour permeance with NBC-required directionality (57-mm-thick specimen) ¹	ng/Pa·s·m ²	≥ 60	71

Note to Table 4.1.2:

¹ From the interior to the exterior side of the wall.

Report Holder

Plastiques Cellulaires Polyform Inc.
454, rue Édouard
Granby, QC

Plant(s)

Granby, QC

Disclaimer

This Report is issued by the Canadian Construction Materials Centre, a program of NRC Construction at the National Research Council of Canada. The Report must be read in the context of the entire CCMC Registry of Product Evaluations, including, without limitation, the introduction therein which sets out important information concerning the interpretation and use of CCMC Evaluation Reports.

Readers must confirm that the Report is current and has not been withdrawn or superseded by a later issue. Please refer to http://www.nrc-cnrc.gc.ca/eng/solutions/advisory/ccmc_index.html, or contact the Canadian Construction Materials Centre, NRC Construction, National Research Council of Canada, 1200 Montreal Road, Ottawa, Ontario, K1A 0R6. Telephone (613) 993-6189. Fax (613) 952-0268.

NRC has evaluated the material, product, system or service described herein only for those characteristics stated herein. The information and opinions in this Report are directed to those who have the appropriate degree of experience to use and apply its contents. This Report is provided without representation, warranty, or guarantee of any kind, expressed, or implied, and the National Research Council of Canada (NRC) provides no endorsement for any evaluated material, product, system or service described herein. NRC accepts no responsibility whatsoever arising in any way from any and all use and reliance on the information contained in this Report. NRC is not undertaking to render professional or other services on behalf of any person or entity nor to perform any duty owed by any person or entity to another person or entity.

Date modified:

2015-09-11

Appendix A – Additional Information

An air barrier material as part of an air barrier system

CCMC has not evaluated the performance of the “AiRclad” air barrier system in conformance with Article 9.25.3.2., Air Barrier System Properties, of Division B of the NBC 2010. However, CCMC’s opinion is that an air barrier system using this material and installed in conformance with the details outlined below and in Plastiques Cellulaires Polyform’s Installation Manual should satisfy the requirements for continuity of the air barrier system in Articles 9.25.3.1., Required Barrier to Air Leakage, and 9.25.3.3., Continuity of the Air Barrier System, of Division B of the NBC 2010.

Discussion

Authorities having jurisdiction (AHJ) should be aware that this system differs from the typical air barrier approach, which uses a flexible membrane as the principal plane of airtightness. In the typical approach, the membrane (i.e. polyethylene sheet) is normally sandwiched between two other materials so that it is not required to resist, on its own, the full force of indoor/outdoor pressure differences induced by stack effect, mechanical systems and, most importantly, wind.

In a system in which a composite of insulation board and membrane is applied to the outer surface of the wall, such as the proposed air barrier system, that composite board must have adequate strength and attachment to resist the anticipated wind pressures. CCMC’s evaluation of the proposed material does not include the evaluation of this strength or the strength of the continuity details. The AHJ must therefore determine whether the proposed air barrier system, described herein, meets the intent of Sentence 9.25.3.2.(1) of Division B of the NBC 2010 as being an effective barrier for the proposed construction in the proposed geographical/climate area. For example, based on their experience, the AHJ may deem the proposed air barrier system adequate for buildings in urban areas, sheltered sites or areas of low wind, but inadequate in areas of high wind and exposed sites in rural or coastal areas.

A checklist for the AHJ to consider will consider that an air barrier system must:

- i. have an acceptable low air leakage rate;
- ii. be continuous;
- iii. be durable;
- iv. have sufficient strength to resist the anticipated air pressure load; and
- v. be buildable in the field.

Installation details

The “AiRclad” material is applied over the structural framing complying with the NBC 2010. It does not contribute to an air barrier system until it is joined to the other components that make up the air barrier system of the building. Plastiques Cellulaires Polyform’s Installation Manual outlines how the proposed material must be joined to the foundation wall, windows and doors, penetrations in the wall and the ceiling air barrier, thus forming the system.

A successful air barrier system installation is predicated on sequencing during construction. Coordination is required during erection of framing and after completion of the air barrier system to ensure that no other trade breaches the integrity of the installed air barrier system.

The proposed air barrier system is defined as possessing the following features:

- i. “AiRclad” material as the principal plane of airtightness;
- ii. accessories, including sealants and CCMC-evaluated sheathing tape to maintain continuity at junctions with penetrations in the wall assembly (i.e. windows, doors, pipes, ducts, electrical outlets, etc.) and in accordance with continuity details in the Plastiques Cellulaires Polyform’s Installation Manual;
- iii. durability, meeting UV- and heat-aging requirements;
- iv. exterior sheathing with specified fasteners and fastening schedule of the product for structural support against anticipated pressure loads; and
- v. buildability in the field by builders following the Plastiques Cellulaires Polyform’s Installation Manual and reviewed by building officials.

Figures 1 to 5 outline typical construction details of an air barrier system. For specific information on the product’s construction and installation details, refer to the “AiRclad” Installation Manual published by the Plastiques Cellulaires Polyform.

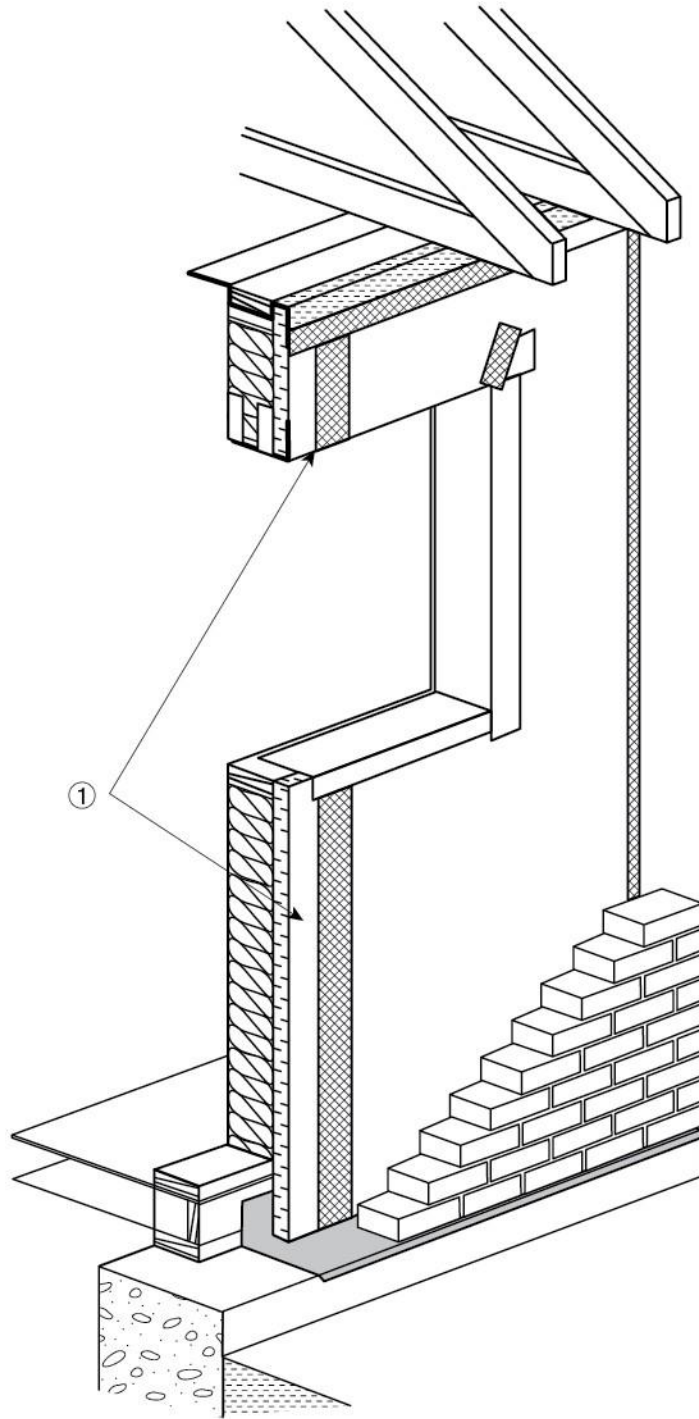

Figure 1a. Exterior wall

1. sheathing tape

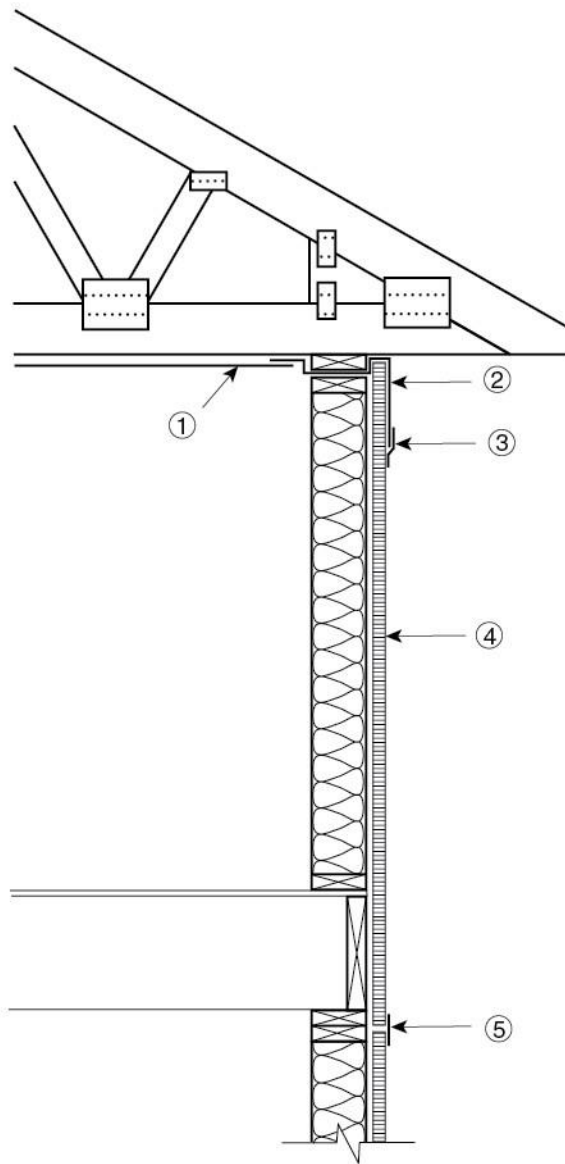

Figure 1b. Exterior wall

- 1. ceiling air/vapour barrier**
- 2. air barrier strip**
- 3. CCMC-evaluated sheathing tape**
- 4. proprietary composite air barrier material**
- 5. CCMC-evaluated sheathing tape**

All joints between the panels must be sealed with CCMC-evaluated sheathing tape. To maintain continuity, the wall membrane must be extended over the top plates and taped to the ceiling membrane.

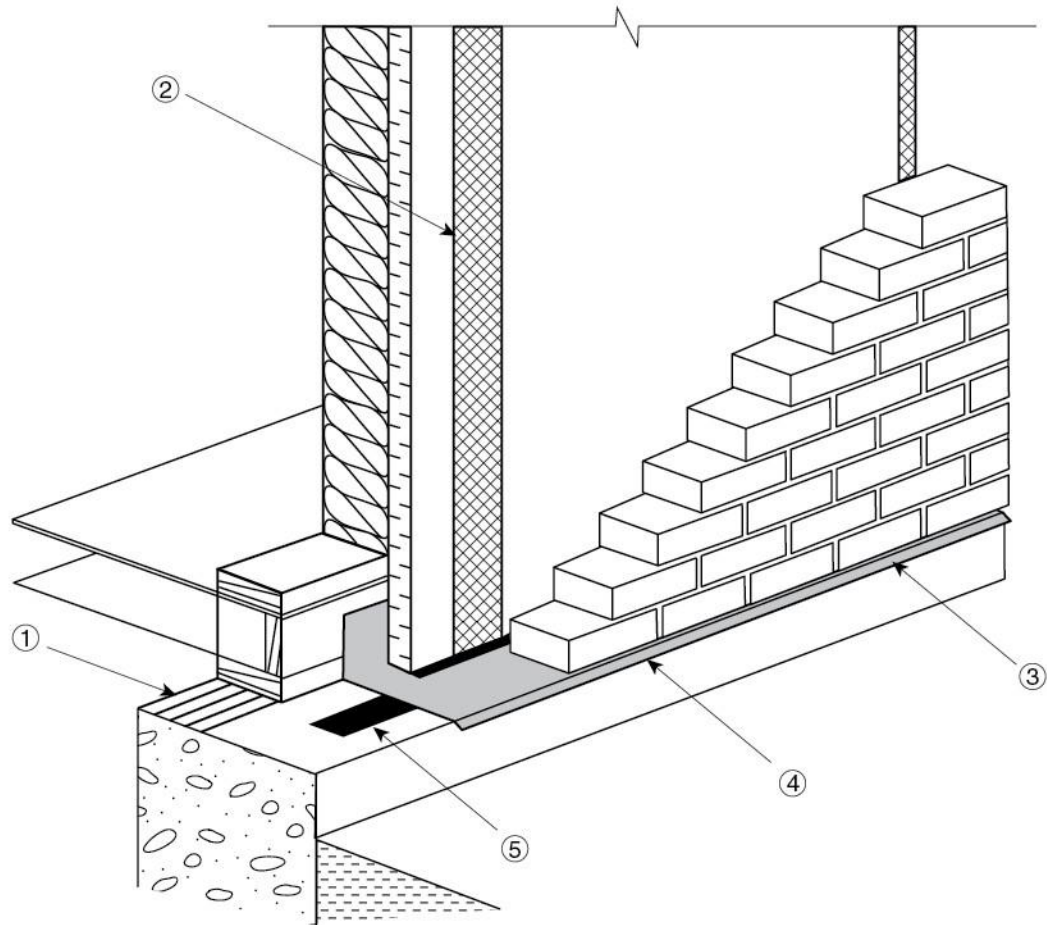

Figure 2a. Foundation/interior wall detail

- 1. sill plate gasket**
- 2. sheathing tape**
- 3. flashing**
- 4. seal the joint between the proprietary composite air barrier material and the flashing**
- 5. the flashing must be sealed to the foundation wall**

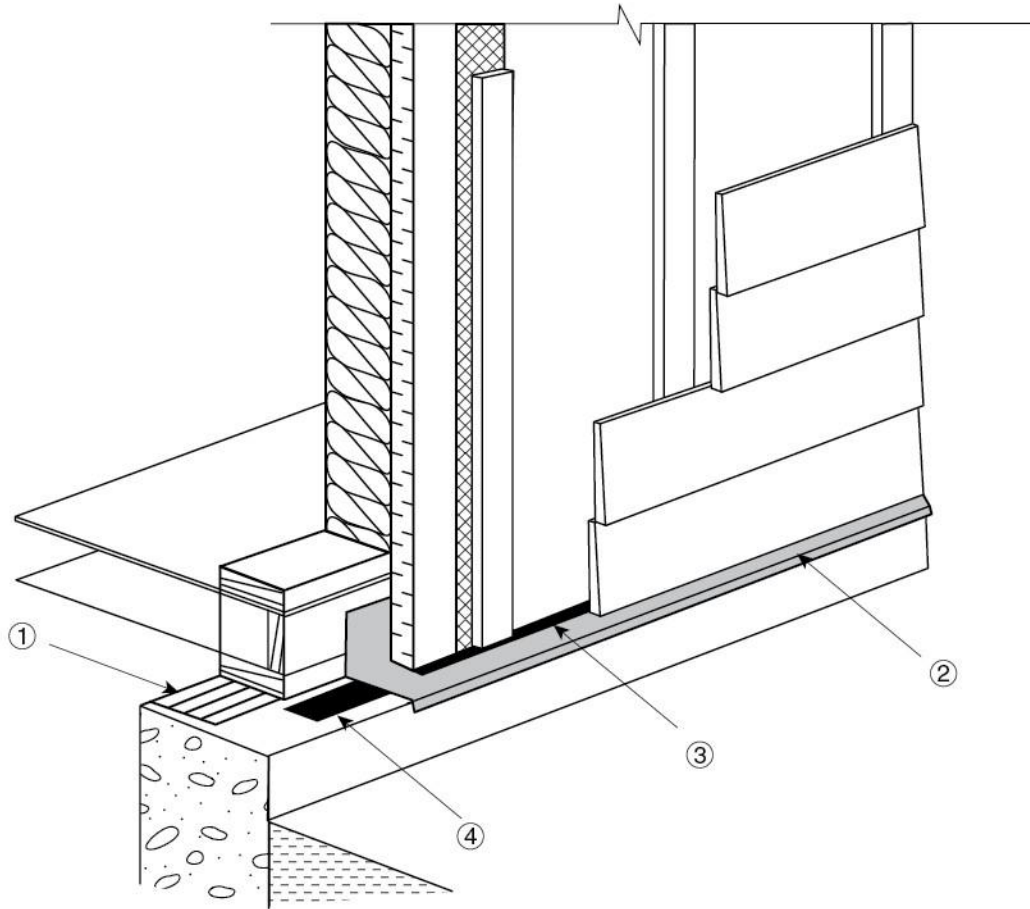

Figure 2b. Foundation/interior wall detail

- 1. sill plate gasket**
- 2. flashing**
- 3. seal the joint between the proprietary composite air barrier material and the flashing**
- 4. the flashing must be sealed on the foundation wall**

The foundation wall forms part of the air barrier system; the proposed membrane must therefore be sealed to the foundation wall to maintain continuity. The sealants used must be compatible with “Tyvek® Homewrap™.” Silicone-based sealants must not be used. To maintain continuity to prevent water infiltration, a seal at the sill must be provided to direct water towards the exterior.

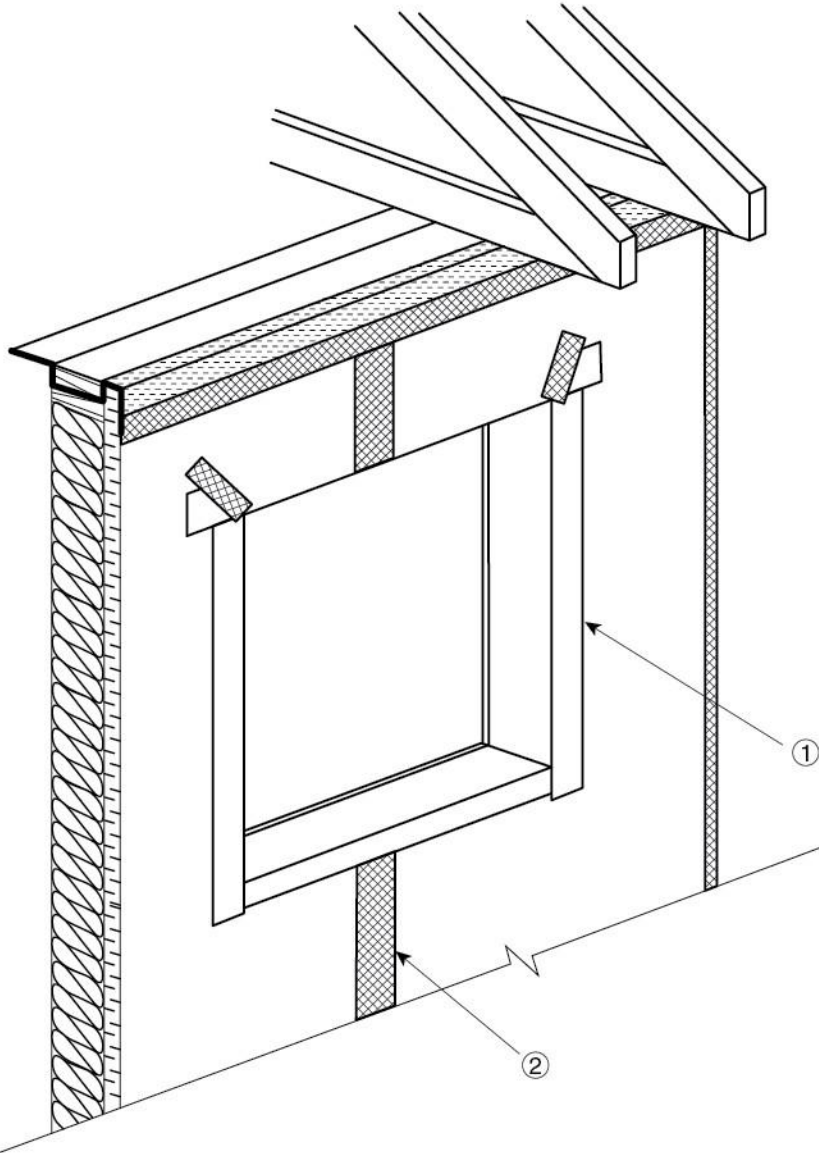

Figure 3a. Continuity at window penetrations

- 1. window flashing tape
- 2. sheathing tape

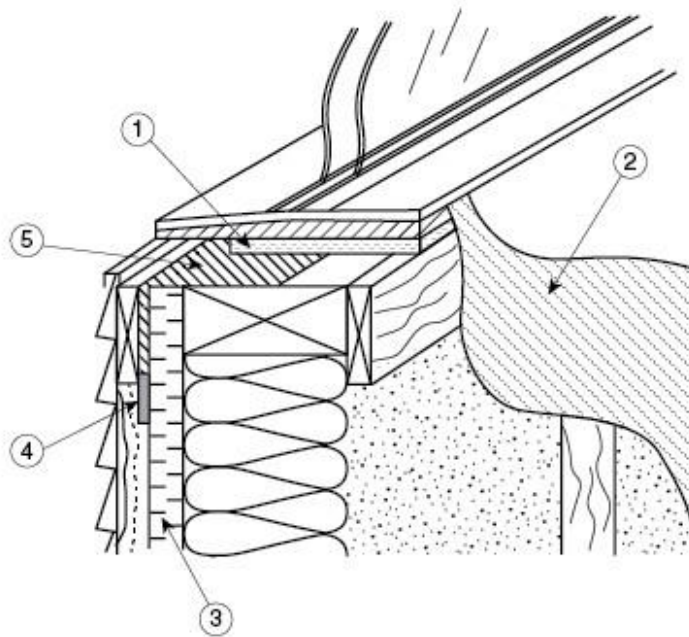

Figure 3b. Continuity at window penetrations

1. sealing material
2. vapour barrier
3. proprietary composite air barrier material
4. sheathing tape
5. air barrier material – strip

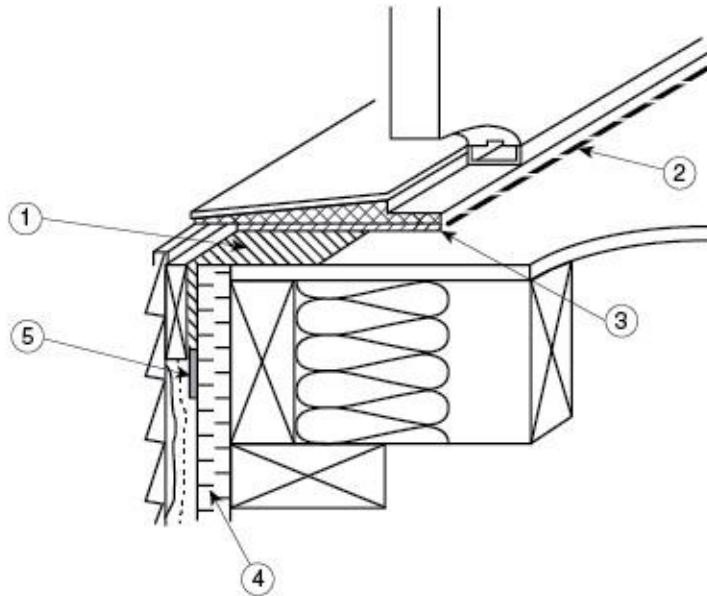

Figure 3c. Continuity at window penetrations

1. air barrier material – strip
2. sealant
3. sealing material
4. proprietary composite air barrier material
5. sheathing tape

The continuity of the proposed membrane must be maintained by sealing the membrane to windows and doors. This may be accomplished by adding a membrane to the frame around the window openings and then sealing it to the windows with either a foam sealant or elastomeric sealant/backer rod. These sealants must be compatible with the surfaces being joined.

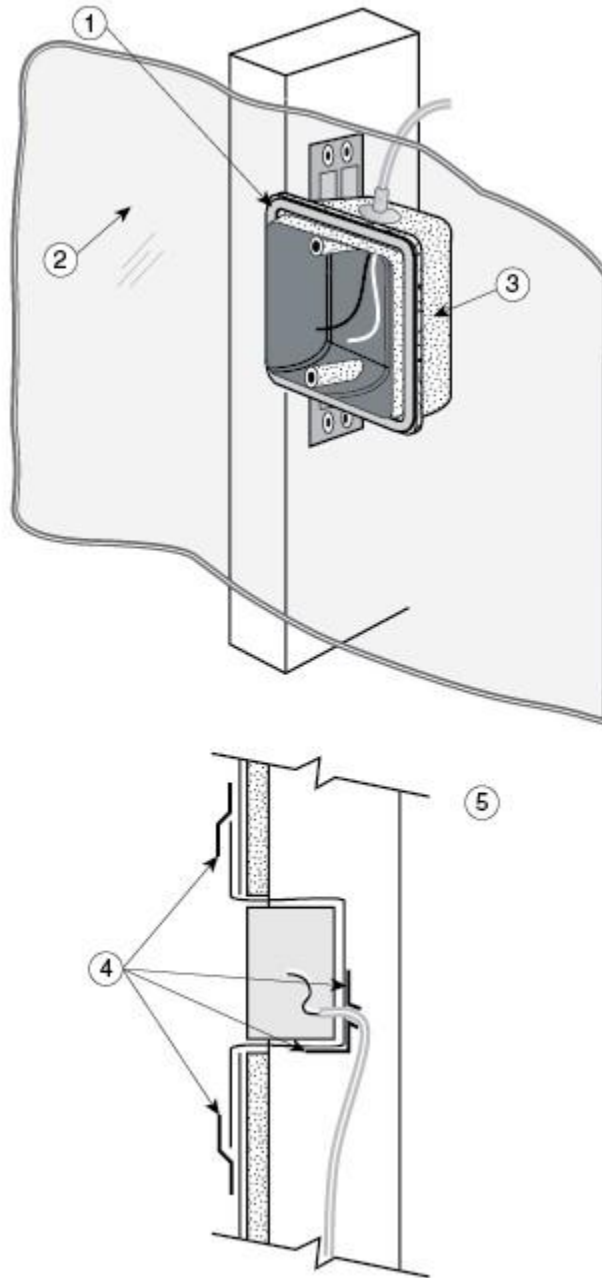

Figure 4. Exterior electrical junction boxes and receptacles

1. snap-on retainer
2. proprietary composite air barrier material
3. airtight plastic electrical box
4. tape seal
5. seal exterior electrical outlet box or use airtight plastic box

All exterior electrical boxes and receptacles that penetrate the proposed air barrier material must be airtight boxes. Otherwise, electrical boxes must be wrapped and sealed to the proposed air barrier material to maintain continuity at these locations.

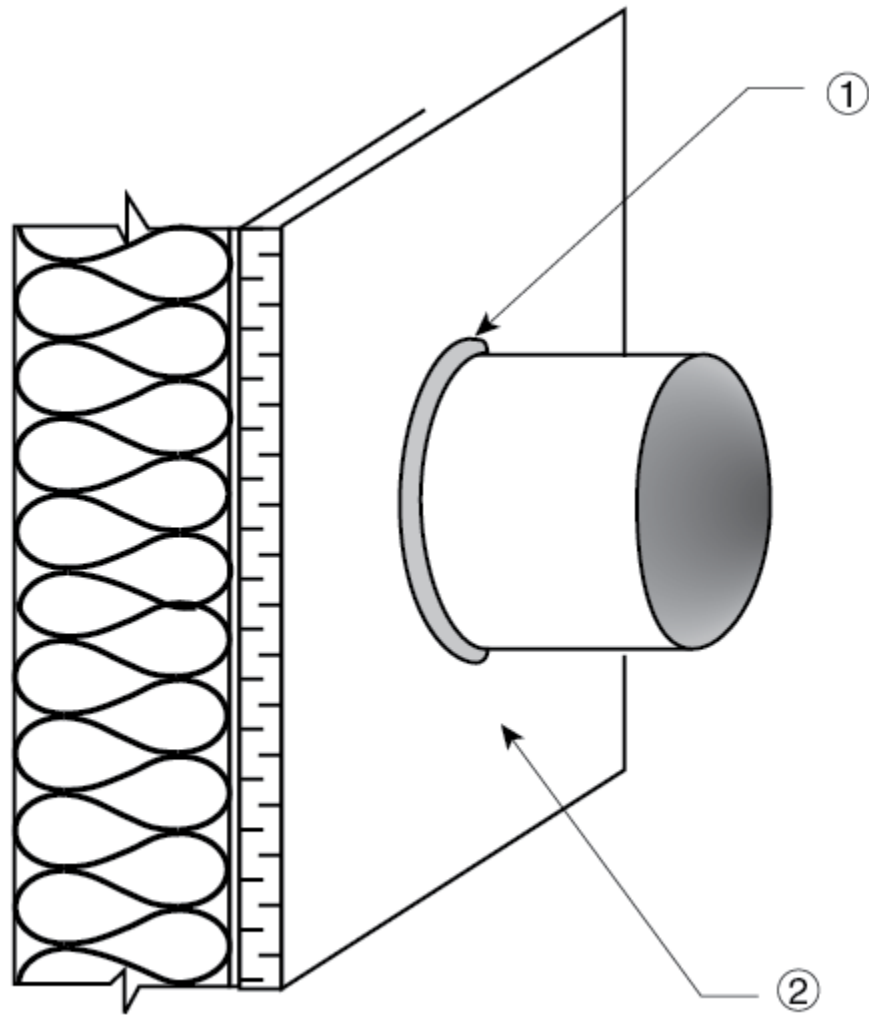

Figure 5. Sealing at penetrations through exterior wall

- 1. seal the gap around penetrations**
- 2. cut the proprietary composite air barrier material to fit around penetrations**

When a pipe, duct or other element penetrates the exterior wall and the proposed air barrier material, it must be sealed to the membrane. Use sealant or CCMC-evaluated sheathing tape, whichever is more appropriate for the element to which it is being sealed.