



Evaluation Report CCMC 13278-R MemBrain™

MasterFormat:	07 26 10.01
Issued:	2007-06-27
Re-evaluation:	2016-07-19
Revised:	2017-09-06
Re-evaluation due:	2019-06-27

1. Opinion

It is the opinion of the Canadian Construction Materials Centre (CCMC) that “MemBrain™,” when used as a vapour barrier and an air barrier system within the exterior walls of the building envelope, in accordance with the conditions and limitations stated in Section 3 of this Report, complies with the National Building Code (NBC) of Canada 2015:

- Clause 1.2.1.1.(1)(b), Division A, as an alternative solution that achieves at least the minimum level of performance required by Division B in the areas defined by the objectives and functional statements attributed to the following applicable acceptable solutions:
 - Article 9.25.3.1., Required Barrier to Air Leakage
 - Sentence 9.25.3.2.(1), Air Barrier System Properties
 - Sentence 9.25.3.2.(2), Material (resist deterioration/durability [F80])
 - Article 9.25.3.3., Continuity of the Air Barrier System
 - Sentences 9.25.4.2.(1), (2) and (3), Vapour Barrier Materials

This opinion is based on the CCMC evaluation of the technical evidence in Section 4 provided by the Report Holder.

Ruling No. 17-07-344 (13278-R) authorizing the use of this product in Ontario, subject to the terms and conditions contained in the Ruling, was made by the Minister of Municipal Affairs and Housing on 2017-08-21 pursuant to s.29 of the Building Code Act, 1992 (see Ruling for terms and conditions). This Ruling is subject to periodic revisions and updates.

2. Description

The product is a 0.05-mm-thick polyamide-6 (nylon-6) film. It is available in folded widths of 2.44 m, 2.74 m, 3.05 m and 3.66 m and is 30 m in length.

This Report addresses the performance of “MemBrain™” as an alternate solution to replace 0.15-mm-thick polyethylene film installed on the warm side of the exterior wall assembly as the designated vapour and air barrier system.

As the air barrier system, the CertainTeed-specified “MemBrain™” components and accessories are:

- “MemBrain™,” a 0.05-mm-thick film, is the principal material in the plane of airtightness.
- Accessories for continuity are:
 - Tremco’s Tremflex 834, a siliconized acrylic latex sealant for sealing joints of “MemBrain™” as a specified caulking sealant conforming to CAN/CGSB-19.0-M77 (ASTM C 834) or equivalent acoustical or silicone-based sealants conforming to ASTM C 920 or ASTM C 834;
 - CCMC-evaluated sheathing tape for small discontinuities in the plane of airtightness;
 - At windows and door penetrations, a one-component spray-in-place polyurethane foam sealant, evaluated by CCMC (see CCMC 13074-R) or listed by CCMC under ULC S710.1 and ULC S710.2 for relevant contact surfaces around penetrations, covering as a minimum vinyl and wood;

- The “MemBrain™” 0.05-mm-thick film installed at ceiling/roof truss locations; and
 - System components for strength to resist wind forces that are provided by “MemBrain™” fastened to the supporting structure by staples onto studs and supported by gypsum wallboard (as with a polyethylene sheet).
- Installation in the field is to be done by trained installers/contractors following the conventional practice for polyethylene sheet installation and CertainTeed-specified accessories in accordance with the CertainTeed Corporation installation manual entitled “CertainTeed MemBrain™ Smart Vapor Retarder Sheeting Air Barrier Installation Instructions for Wood Framing,” June 2007, No. 30-28-137.

3. Conditions and Limitations

The CCMC compliance opinion in Section 1 is bound by “MemBrain™” being used in accordance with the conditions and limitations set out below.

3.1 Vapour Diffusion Control – Designated Vapour Barrier

As the designated vapour barrier installed on the warm side of an exterior wall assembly, the NBC 2015 requires a water vapour permeance (WVP) not greater than 60 ng/Pa·s·m² for indoor spaces maintained below 35% relative humidity (RH) over the heating season. For indoor spaces maintained over 35% RH, the vapour barrier must be designed in accordance with Part 5 of the NBC. The analysis below is considered for interior conditions up to 60% RH.

The “MemBrain™” film has a WVP that is dependent on the ambient RH, so it has a dynamic WVP that changes with the ambient conditions within the exterior wall cavity. See Figure 1.

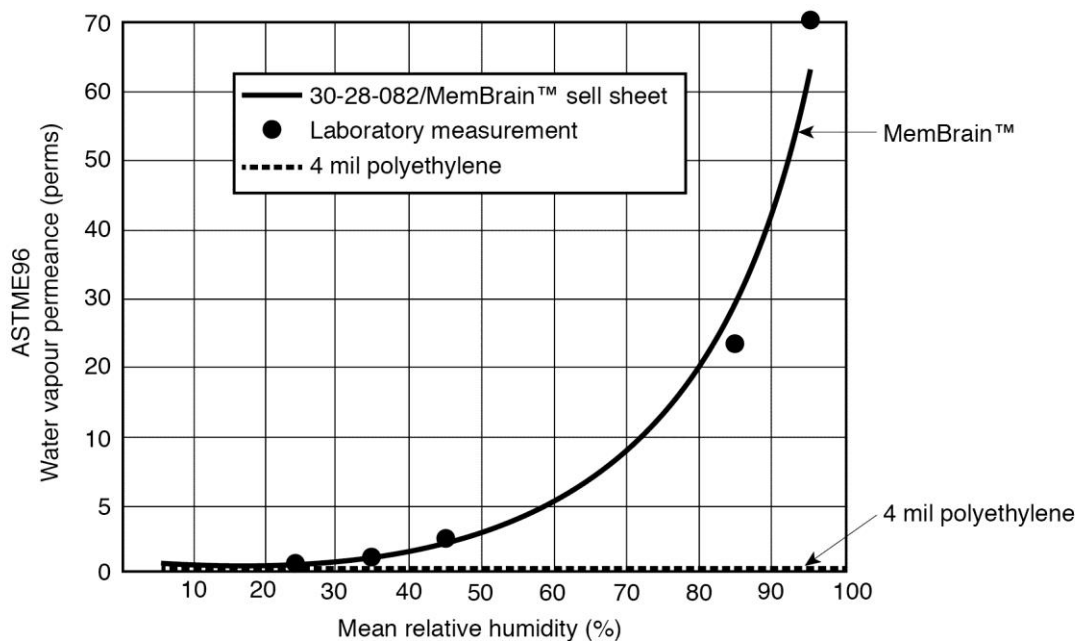

Figure 1. WVP of “MemBrain™” compared to 0.10 mm (4 mil) polyethylene (1 perm = 57.45 ng/Pa·s·m²)

Figure 1 illustrates that the WVP of “MemBrain™” increases exponentially as the ambient RH increases. Therefore, as the water vapour permeance increases within the wall cavity, water vapour may diffuse through the interior drywall into the interior space. Both “MemBrain™” and 0.10 mm (4 mil) comply with the Code-prescribed maximum water vapour permeance of 60 ng/Pa·s·m² (~1 perm), at 25% mean relative humidity (dry cup) in Figure 1.

This varying WVP required the computer modeling to verify compliance to, at the time of the original evaluation, to the NBC 2005 in accordance with the principles of Part 5. The modeling parameters and wall assumptions are presented in Section 4.2 below. The moisture content (MC) of the wood-based sheathing and drywall were the focus of the modeling.

The use limitations of “MemBrain™” as the designated vapour barrier are:

- The “MemBrain™” film must be protected from direct ultraviolet (UV) exposure and covered with interior gypsum wallboard within 7 days.

- The wood-frame wall assembly must have a maximum 12.5 mm (11.1 mm typ.) thickness of exterior plywood or OSB sheathing installed with joints at stud locations (i.e., no open horizontal joints and just two layers of sheathing paper is not permitted).
- For buildings where the moisture index (MI) < 1.0, the interior drywall must be painted with a primer and two coats of latex (1100 ng/Pa·s·m²) or acrylic paint (400 ng/Pa·s·m²).
- For a MI > 1.0, the interior drywall must also be painted with a primer and two coats of latex (1100 ng/Pa·s·m²) or acrylic paint (400 ng/Pa·s·m²), except in cases where there is a potential for rain penetration into the wall cavity.¹ In the latter case, a primer and two coats of latex must be applied.
- High water vapour resistant interior wall finishes must be avoided, such as ceramic wall tile and vinyl wallpaper.

3.2 Air Leakage Control – Designated Air Barrier System

The “MemBrain™” air barrier system has demonstrated sufficient low air permeance, when installed as an alternate to the conventional 0.15-mm (6-mil) thick polyethylene sheet, this thickness for strength against wind pressures, to meet the intent of Section 5.4. and Article 9.25.3.2. of the NBC 2015. This conformance applies for buildings with an indoor environment of 20°C and winter design of 35% RH or other RH as covered in the vapour diffusion control review above.

The “MemBrain™” air barrier system has demonstrated sufficient strength as per Article 9.25.3.2. of the NBC 2015 to be used for low-rise buildings in geographical locations where the Q₅₀ value does not exceed 0.60 kPa. The Q₅₀ value is the hourly wind pressure for a 1-in-50-year return period found in Appendix C of the NBC 2015.

The CertainTeed-specified installation details are sufficient to address the continuity details required in Article 9.25.3.3. of the NBC 2015 following conventional practice for installation of the polyethylene air barrier system.

To conform in terms of air leakage control, strength and continuity, the “MemBrain™” air barrier system must be:

- Protected from direct UV exposure and covered with interior gypsum wallboard within 7 days;
- Installed with 12.5 mm (1/2 in.) staples over wood-frame stud walls and covered with gypsum wallboard;
- Installed according to the CertainTeed “MemBrain™” air barrier system installation manual by trained installers/contractors following the conventional practice for polyethylene sheet air/vapour installation and CertainTeed-specified accessories in accordance with the CertainTeed Corporation installation manual entitled “CertainTeed MemBrain™ Smart Vapor Retarder Sheeting Air Barrier Installation Instructions for Wood Framing,” June 2007, No. 30-28-137.
- The product must be clearly identified with the phrase “CCMC 13278-R.”

4. Technical Evidence

Testing to the CCMC Technical Guides for MF 07 26 10.01, *Vapour Barrier with RH-Dependent Water Vapour Permeance*, and MF 07 27 09.01, *Air Barrier System for Exterior Walls of Low-Rise Buildings*, was conducted at an independent laboratory recognized by CCMC. The results of testing “MemBrain™” as a vapour barrier and air barrier system are summarized as an alternative solution in compliance with the NBC 2015. The Report Holder has submitted test results and other data for the CCMC evaluation. The corresponding test results are summarized below.

4.1 Performance Requirements

The “MemBrain™” material is an innovative nylon-6 material; the durability of the 0.05 mm (2 mil) thick nylon-6 material and its vapour diffusion control properties needed to be determined and assessed. Table 4.1.1 shows the results of testing the durability/service life in a building by addressing an initial exposure and the subsequent aging within the wall assembly. The nylon-6 is susceptible to UV light and must be covered within 7 days as per the installation limitations and conditions.

The vapour diffusion control performance is addressed in Section 4.2.

1. Rain penetration moisture finding its way into the wall cavity would be considered a failure of the cladding and second plane of protection required by the NBC. In this scenario, the exposure to moisture of the drywall backing would be equivalent to the airtight drywall approach (ADA) which is a Code-accepted solution.

Table 4.1.1 Results of Testing the Vapour Barrier Permeance and Durability of the Product

Property ¹	UV (Level 1) and Heat Aging	UV (Level 2) and Heat Aging	Requirement	Result
Tensile strength, WVP and air permeance	Report original values	Report original values	No more than 15% reduction in tensile strength from original values and 15% increase in WVP and air permeance or Percentage loss of strength or increase in WVP and air permeance are no greater than control specimens	Pass
UV testing (2 levels)	48 h	72 h ²		
Tensile strength, WVP and air permeance	Report residual values after 48 h UV exposure	Report residual values after 72 h UV exposure		
Heat aging 1 of UV-exposed specimens at 90°C	168 h	168 h		
Tensile strength, WVP and air permeance	Report residual values after 48 h UV exposure and 168 h heat aging	Report residual values after 72 h UV exposure and 168 h heat aging		
Heat aging 2 of UV-exposed and 168 h heat-aged specimens at 90°C	168 h	168 h		
Tensile strength, WVP and air permeance	Report residual values after 48 h UV exposure and 336 h heat aging	Report residual values after 72 h UV exposure and 336 h heat aging		

Notes to Table 4.1.1:

1. The values for each specimen (identified by the location on the roll) must be reported along with the average value. In addition, the tensile strength stress-strain curves for each specimen must be presented.
2. This value is set to establish a maximum upper-end for exposure limitation.

4.2 Computer Modeling of “MemBrain™” Vapour Diffusion Control

For the computer modeling two materials were selected for comparison:

1. Acceptable solution: 0.10 mm (4 mil) polyethylene or 60 ng/Pa·s·m², maximum water vapour permeance NBC 2015 requirement (i.e., vapour barrier paint over drywall in an airtight drywall approach); and
2. Alternate solution: Proprietary 0.05-mm-thick polyamide-6 (nylon-6) film.

The exterior wall configuration is shown in Figure 2 while Figures 3 and 4 illustrate the indoor conditions.

The simulated exterior conditions represented the actual weather conditions for Shearwater (NS), Vancouver (BC), Ottawa (ON) and Winnipeg (MB). The interior finishes considered were painted drywall (i.e., primer and two coats of latex [1100 ng/Pa·s·m²] or acrylic paint [400 ng/Pa·s·m²]) and unpainted drywall.

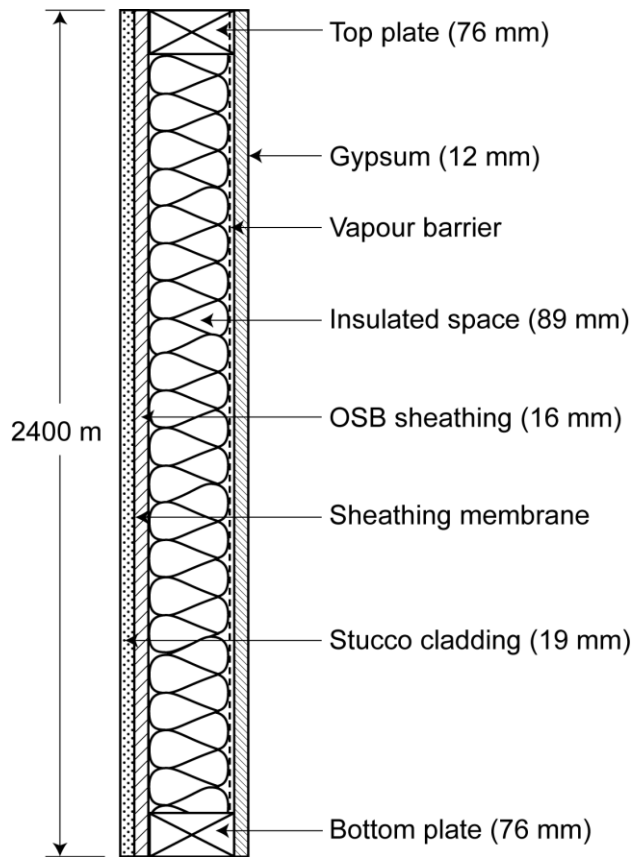

Figure 2. Wall configuration

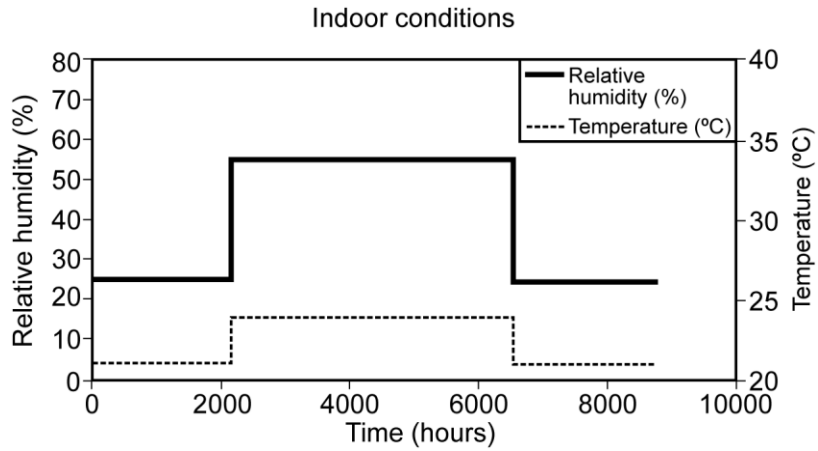

Figure 3. Computer modeling No. 1 – indoor conditions

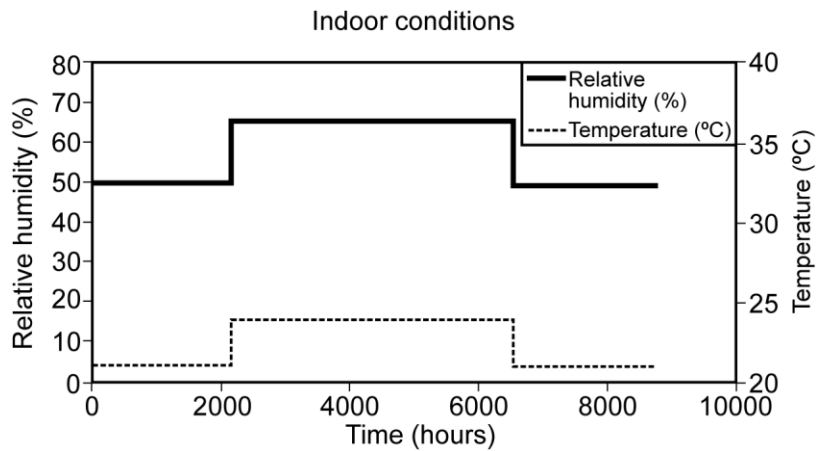

Figure 4. Computer modeling No. 2 – indoor conditions

Table 4.2.1 Results of Computer Modeling

Coastal Climates (MI > 1)		
Condensation Location	Low Interior RH ($\leq 35\%$)	High Interior RH ($\leq 60\%$)
	No Incidental Rain Penetration	
Moisture content (MC) of OSB exterior sheathing	Pass ¹	Pass
MC of gypsum wallboard	Pass	Pass
With Incidental Rain Penetration²		
MC of OSB exterior sheathing	Pass	Pass
MC of gypsum wallboard	Latex only ²	Latex only ²
Non-coastal Climates (MI < 1)		
Condensation Location	Low Interior RH ($\leq 35\%$)	High Interior RH ($\leq 60\%$)
	No Incidental Rain Penetration	
MC of OSB exterior sheathing	Pass	Pass
MC of gypsum wallboard	Pass	Pass
With Incidental Rain Penetration		
MC of OSB exterior sheathing	Pass	Pass
MC of gypsum wallboard	Pass	Pass

Notes to Table 4.2.1:

1. The “Pass” designation relates to the moisture content (MC) within the OSB or the interior gypsum wallboard, being within a range that is deemed acceptable or is equivalent to a Code-prescribed acceptable solution (i.e., airtight drywall approach (ADA)). This acceptable “Pass” performance applies to interior gypsum wallboard that is painted with a primer and two coats of latex (1100 ng/Pa-s-m²) or primer with two coats of acrylic paint (400 ng/Pa-s-m²).
2. In cases where there may be incidental rain penetration, a primer and two coats of acrylic paint (400 ng/Pa-s-m²) do not perform satisfactorily. However, the incidental rain penetration moisture would be considered a failure of the cladding system (not failure of the designated vapour barrier) and should be rectified. Note that the ADA acceptable solution would also not perform well with moisture in the cavity.

4.3 “MemBrain™” Air Barrier System

The air barrier system performance has been demonstrated by the “MemBrain™” air barrier system to meet the criteria of the CCMC Technical Guide MF 07 27 09.01, *Air Barrier System for Exterior Walls of Low-Rise Buildings*. To qualify, a conforming air barrier system must:

- i) have an acceptable low air leakage rate;
- ii) be continuous;
- iii) be durable;
- iv) have sufficient strength to resist the anticipated air pressure load; and
- v) be buildable in the field.

Table 4.3.1 Results of Testing the Air Leakage Rate of the Product

Property		Requirement	Result
Wood-frame wall specimen	No. 1 – opaque wall	Air leakage rate ¹ at 75 Pa ΔP ≤ 0.05 L/(s·m ²) ²	Pass
	No. 2 – continuity at penetrations	Air leakage rate at 75 Pa ΔP ≤ 0.055 L/(s·m ²)	Pass ³
	No. 3 – opaque wall with vertical joint	Air leakage rate at 75 Pa ΔP ≤ 0.055 L/(s·m ²)	Pass

Notes to Table 4.3.1:

1. The air leakage rate of the specimen is determined after structural aging of the air barrier system. Structural aging of the air barrier system was conducted to qualify the air barrier system for a design structural wind load of $Q_{50} = 0.60$ kPa (NBC climatic data in Appendix C) 1-in-50-year return period. The air barrier system was subjected to a loading schedule involving one-hour sustained positive and negative pressure set at 0.60 kPa, 2 000 cycles of positive and negative pressure set at 0.80 kPa, and a gust wind of positive and negative pressure of 1.2 kPa.
2. The air leakage rate requirement is based on the following permissible air leakage rate, which is deemed to meet the intent of the NBC for air barrier system performance.

Water Vapour Permeance of Outermost Layer of Wall Assembly (ng/Pa·s·m ²)	Maximum Permissible Air Leakage Rates (L/s·m ²) @ 75 Pa
15 < WVP ≤ 60	0.05
60 < WVP ≤ 170	0.10
170 < WVP ≤ 800	0.15
> 800	0.20

3. The air leakage rate was 0.03 L/(s·m²) before aging and 0.069 L/(s·m²) after aging. Leakage near ducting was determined to be the source of the leakage and revised sealing details are intended to address this defect. The air leakage values are within the acceptable test range and are deemed a pass.

For more information on the CCMC Technical Guide requirements and how they relate to the NBC requirements, please see the NRC publication, NRCC 4065, ISBN 0-60-16862-6, March 1997.

Figures 5 to 9 outline typical construction details to be reproduced in the field as part of the installation of the “MemBrain™” air barrier system. The wall specimens that were tested were representative of these details. See “CertainTeed MemBrain™ Smart Vapor Retarder Sheeting Air Barrier Installation Instructions for Wood Framing,” June 2007, No. 30-28-137.

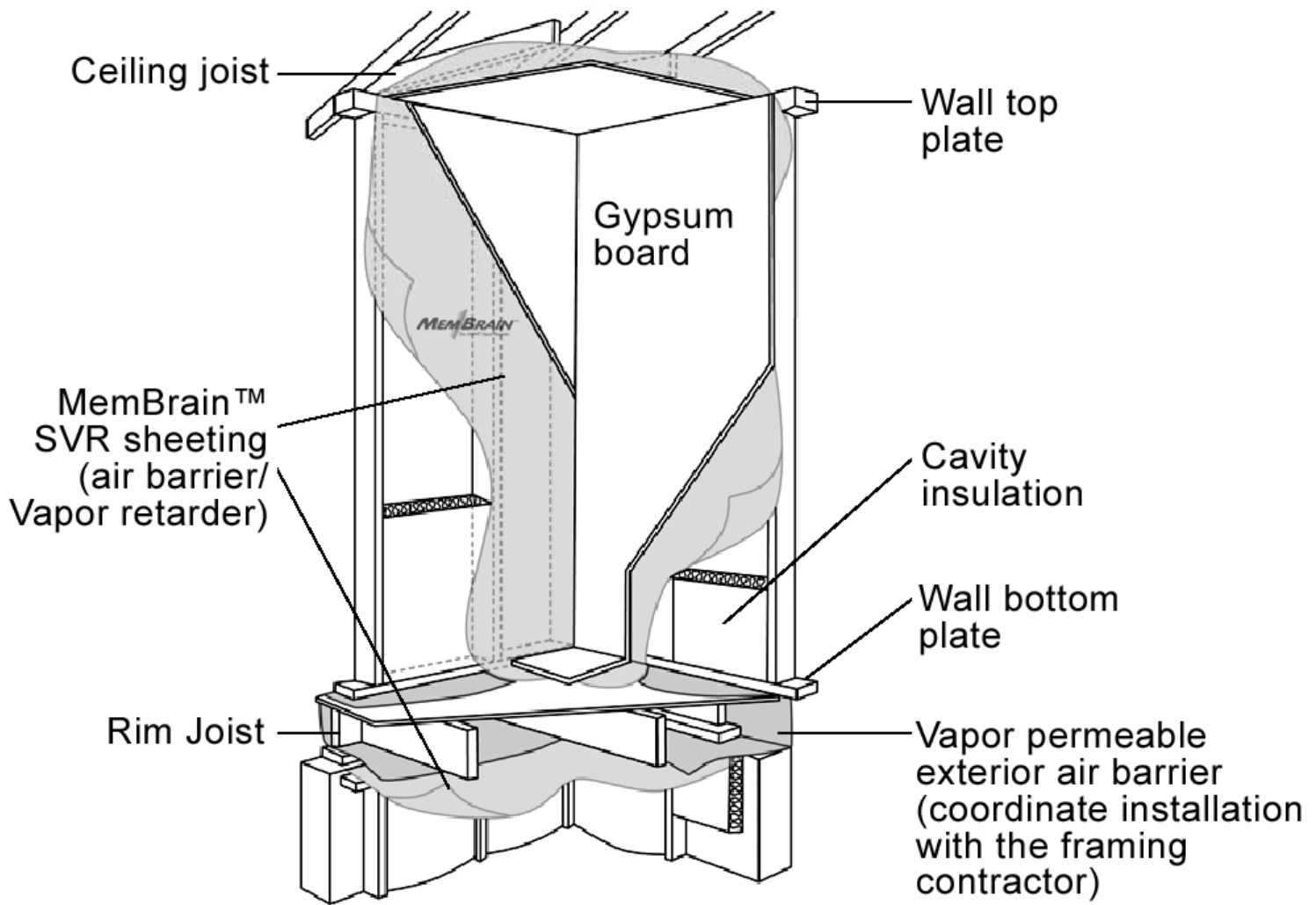

Figure 5. “MemBrain™” air barrier system

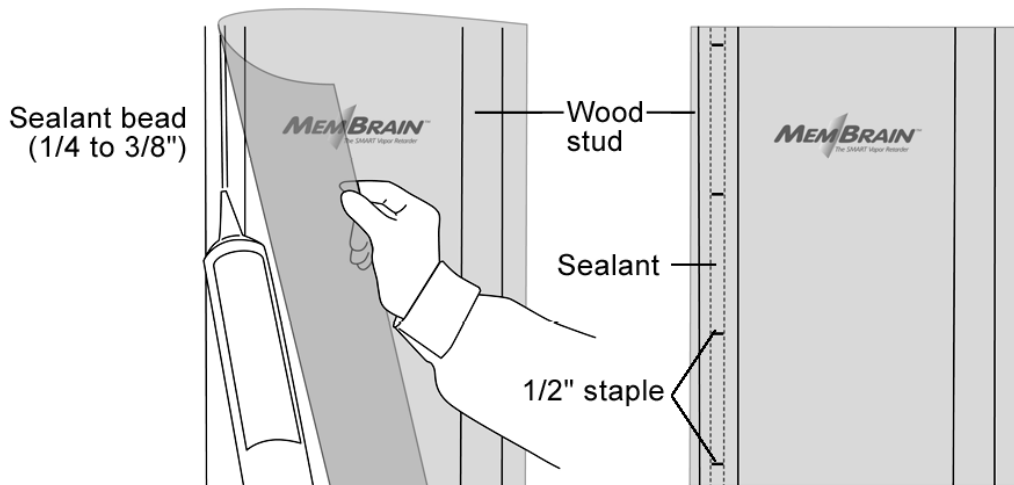
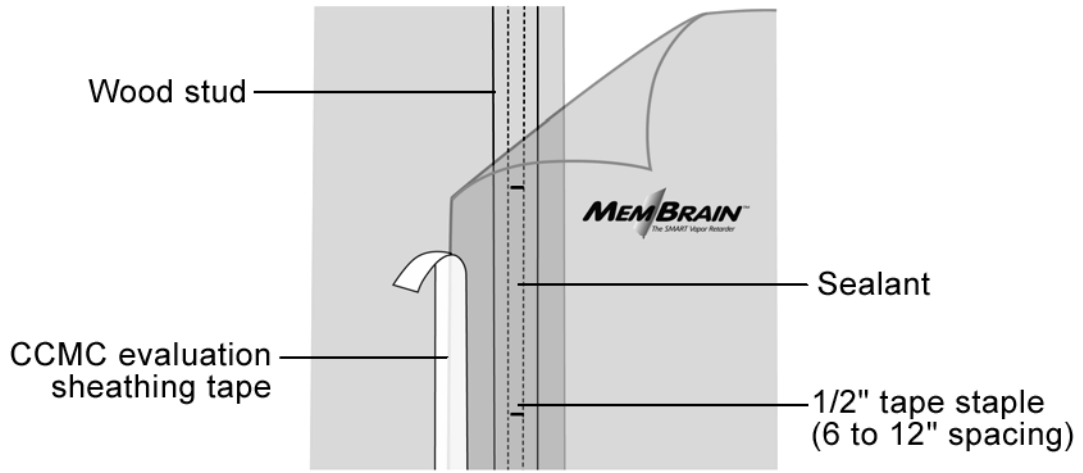

Figure 6. "MemBrain™" attachment to studs and overlapping details

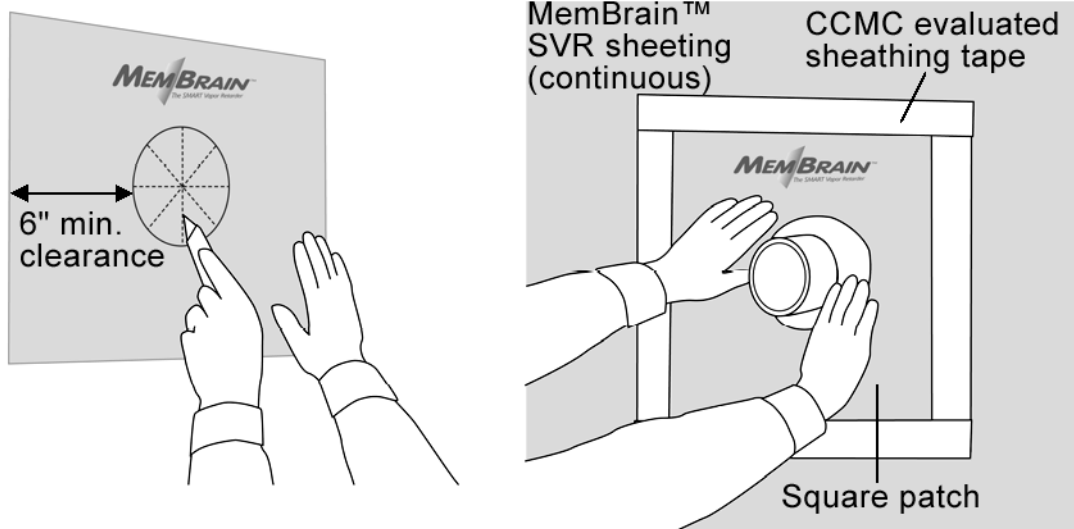
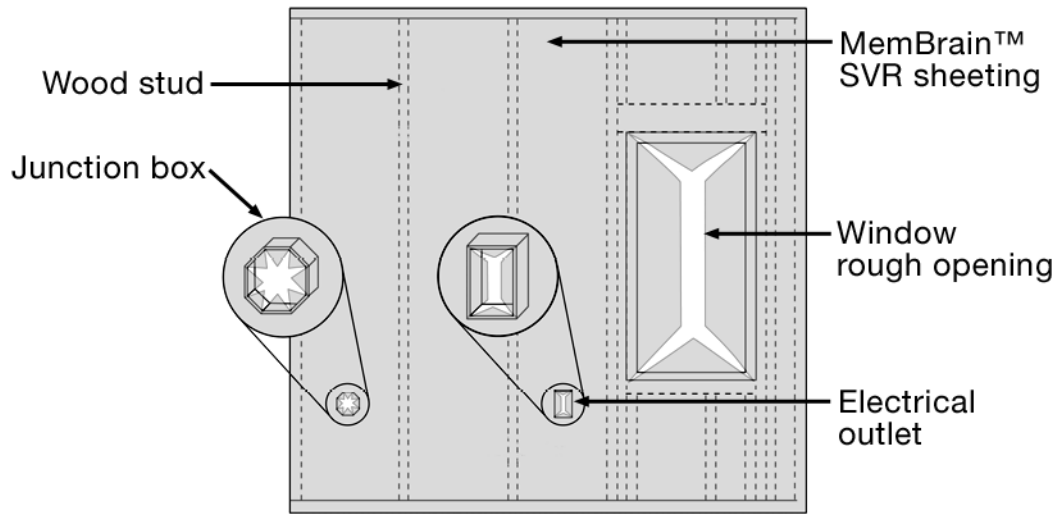

Figure 7. “MemBrain™” details for continuity at junctions of penetrations

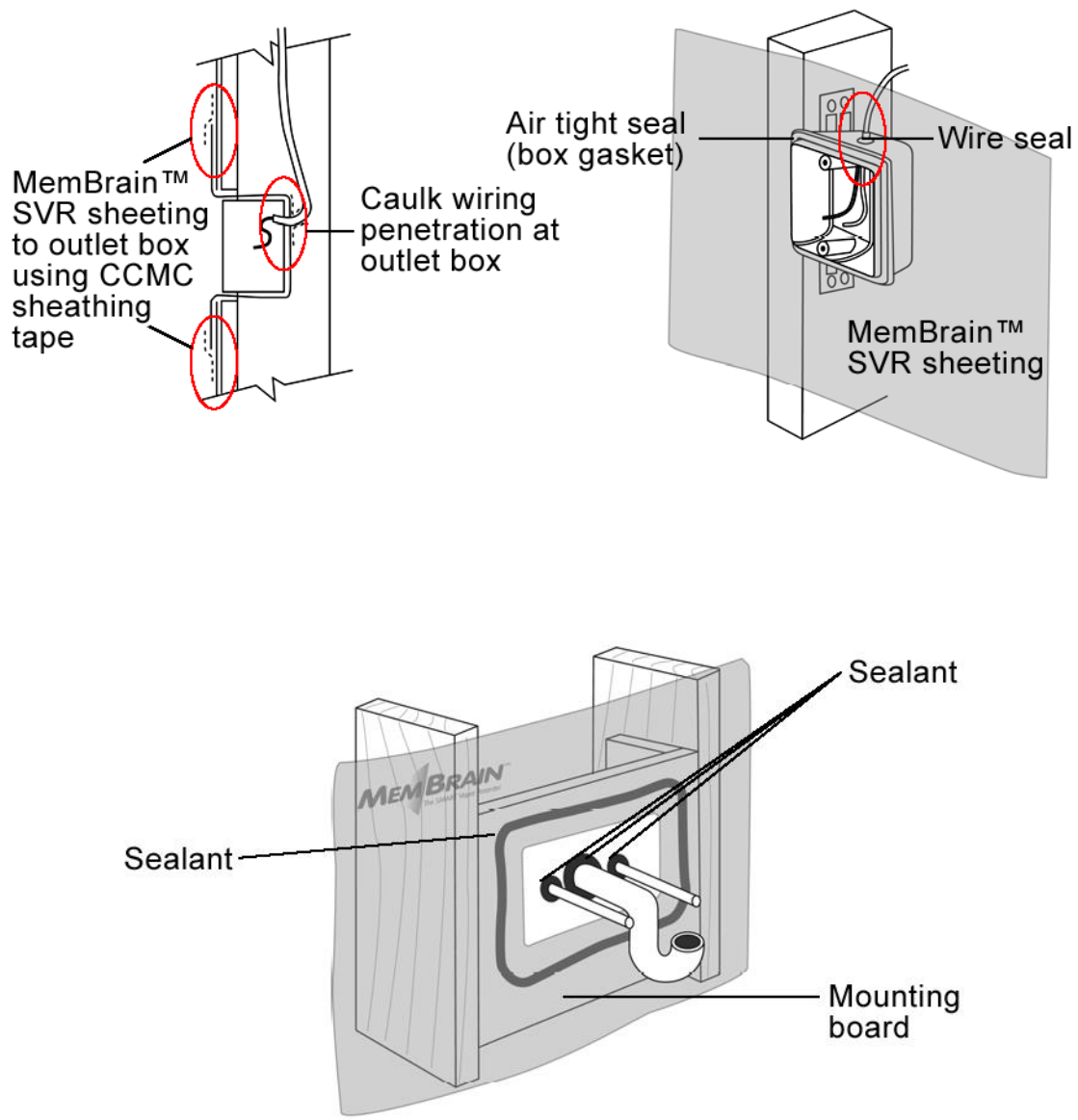

Figure 8. “MemBrain™” details for sealing plumbing and electrical penetrations

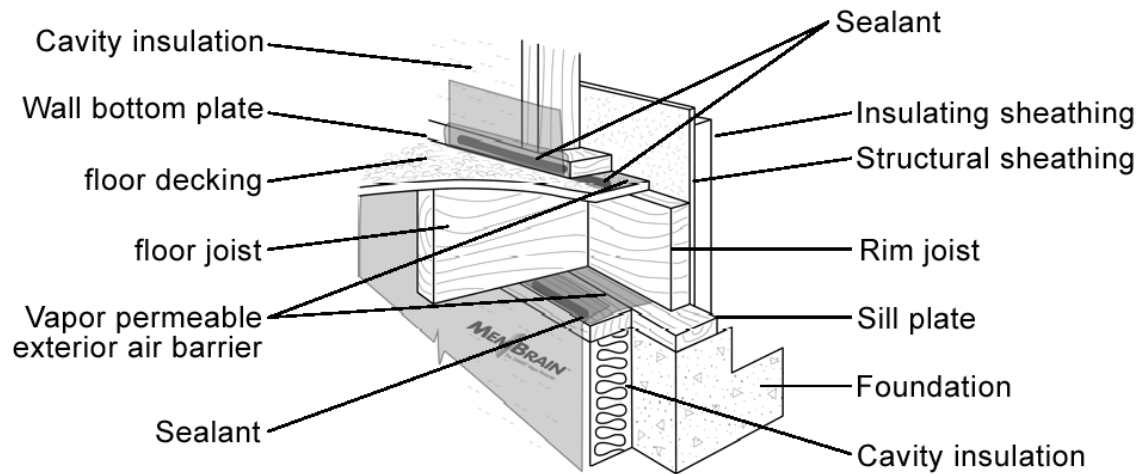
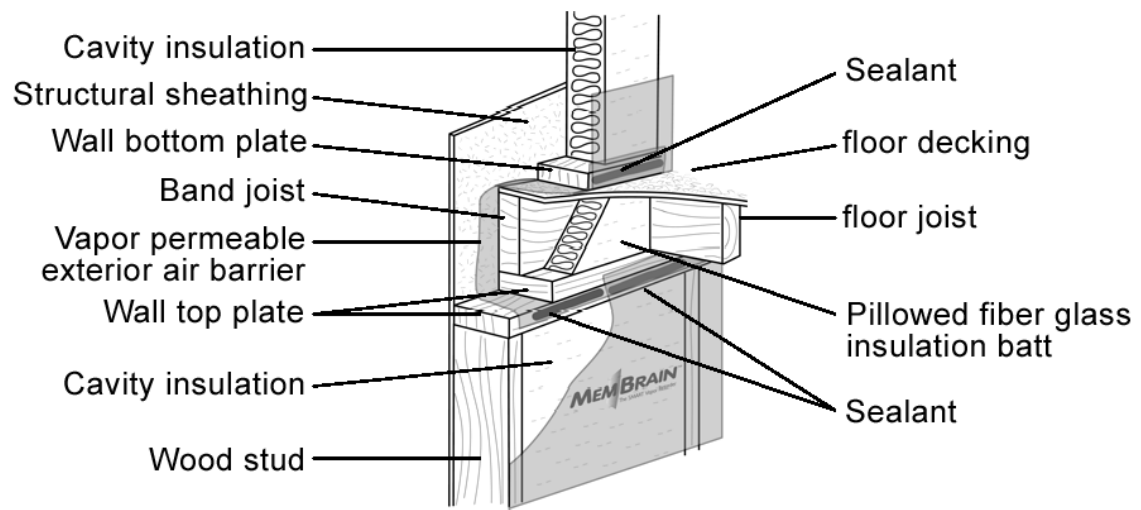
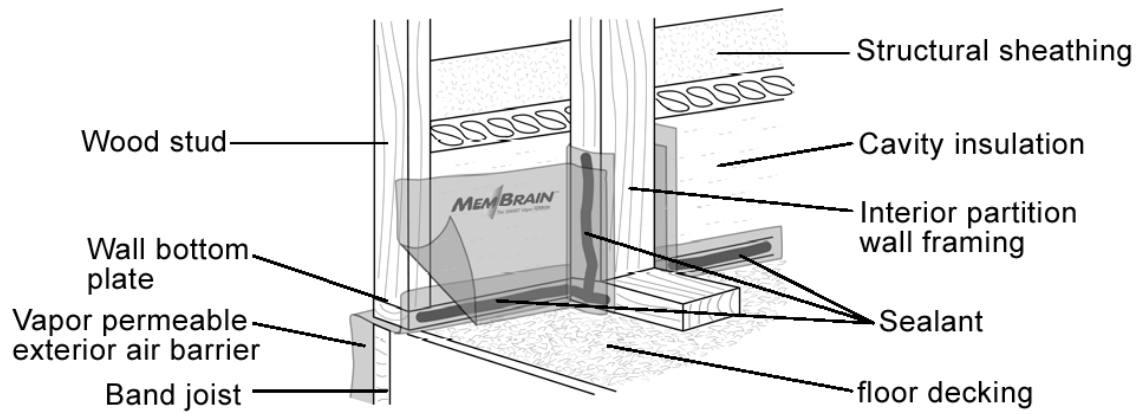

Figure 9. “MemBrain™” continuity details across a floor plate and at intersecting interior walls

4.4 Additional Performance Data Requested by the Report Holder

Data in this section does not form part of the CCMC opinion in Section 1.

The Report Holder requested that this CCMC Report include testing to CGSB 51.33-M89, “Vapour Barrier Sheet, Excluding Polyethylene, for Use in Building Construction.” Although this 1989 standard is not applicable to nylon-6 material, the test results are presented here for information.

Table 4.4.1 Testing of Product to CGSB 51.33-M89, Type 2

Property	Requirement	Result
Sheet width	Not \leq 99% of specified	Pass
Sheet length	No less than that specified	Pass
Pliability	Must not crack over mandrel	Pass
Tensile strength and elongation	Tensile strength MD, ¹ 12 MPa	50 MPa
	Tensile strength XD, ¹ 8 MPa	53 MPa
	Elongation, MD 225%	399%
	Elongation, XD 350%	444%
Water vapour permeance	ASTM E 96 Procedure A < 45 ng/Pa·s m ² before aging	41.8
	< 60 ng/Pa·s m ² after aging ²	42.8

Notes to Table 4.4.1:

1. MD = machine direction; XD = cross-machine direction.
 2. The accelerated aging test conducted was 10 cycles of 3 h in 21°C water, 18 h at 20°C air and 3 h at 50°C.
-

4.5 Additional Health and Safety Data Identified by Third Parties

No additional health and safety requirements have been identified by others at this time.

Report Holder

CertainTeed Corporation
20 Moores Rd.
Malvern, PA 19355
USA

Telephone: 1-800-233-8990

Email: salesupportgroup@certainteed.com

Web site: www.certainteed.com

Plant(s)

98 Westwood Road
Pottsville, Pennsylvania 17901
USA

Disclaimer

This Report is issued by the Canadian Construction Materials Centre, a program of NRC Construction at the National Research Council of Canada. The Report must be read in the context of the entire CCMC Registry of Product Evaluations, including, without limitation, the introduction therein which sets out important information concerning the interpretation and use of CCMC Evaluation Reports.

Readers must confirm that the Report is current and has not been withdrawn or superseded by a later issue. Please refer to http://www.nrc-cnrc.gc.ca/eng/solutions/advisory/ccmc_index.html, or contact the Canadian Construction Materials Centre, NRC Construction, National Research Council of Canada, 1200 Montreal Road, Ottawa, Ontario, K1A 0R6. Telephone (613) 993-6189. Fax (613) 952-0268.

NRC has evaluated the material, product, system or service described herein only for those characteristics stated herein. The information and opinions in this Report are directed to those who have the appropriate degree of experience to use and apply its contents. This Report is provided without representation, warranty, or guarantee of any kind, expressed, or implied, and the National Research Council of Canada (NRC) provides no endorsement for any evaluated material, product, system or service described herein. NRC accepts no responsibility whatsoever arising in any way from any and all use and reliance on the information contained in this Report. NRC is not undertaking to render professional or other services on behalf of any person or entity nor to perform any duty owed by any person or entity to another person or entity.

Date modified:
2017-09-06